

Adaptive Gait Pattern Generation of a Powered Exoskeleton by Iterative Learning of Human Behavior

Kyeong-Won Park, Jeongsu Park, Jungsu Choi, and Kyoungchul Kong

Abstract—Several powered exoskeletons have been developed and commercialized to assist people with complete spinal cord injury. For motion control of a powered exoskeleton, a normal gait pattern is often applied as a reference. However, the physical ability of paraplegics and the degrees of freedom of powered exoskeletons are totally different from those of people without disabilities. Therefore, this paper introduces a novel gait pattern depart from the normal gait, which is proper to the paraplegics. Since a human is included, the system of the powered exoskeleton has lots of motion uncertainties that may not be perfectly predicted resulting from different physical properties of paraplegics (SCI level, muscular strength of the upper body, body parameters, inertia), actions from crutches (position and timing to put), several types of training (period, methodology), etc. Then, to find a stable and safe gait pattern adapted to the individual user, an iterative way to compensate the gait pattern is also required. In this paper, human iterative learning algorithm, which utilizes the accumulated data during walking to adjust the gait trajectories is proposed. Additionally, the effectiveness of the proposed gait pattern is verified by human walking experiments.

I. INTRODUCTION

According to the report of World Health Organization, between two hundred fifty thousand and five hundred thousand worldwide people become spinal cord injury (SCI) patients every year[1]. Less than only 1% of SCI patients can experience complete neurological recovery by hospital discharge, but the most of the SCI patients are diagnosed as paraplegia[2]. The mortality rate of the SCI patients is 2 to 5 times higher than non-SCI patients because they suffer from the side effects of sitting or lying for a long term period[3], which frequently causes serious damages on the skin, the digestive system, etc. Rehabilitation of the SCI patients, however, is able to significantly reduce mortality rate and improve life expectancy[4], [5]. Also, the rehabilitation can help the patients not only to maintain their health condition, but also enable daily living activities. For these purposes, a powered exoskeleton is receiving great attention as an assistive device for the people with disabilities in walking.

Requirements of a successful powered exoskeleton for paraplegics may include: robust gait stability, balance of the system, gait speed, safety and practicality (i.e., size, volume, weight, energy efficiency, and comfort). In this

aspect, a number of powered exoskeletons are currently being developed such as ReWalk manufactured by ReWalk Robotics[6], [7], Ekso manufactured by Ekso Bionics[8] and Indego manufactured by Parker Hannifin[9].

Powered exoskeletons developed further apply the pre-defined joint angle trajectories such as the joint angle trajectories of people without disabilities (i.e., the normal gait pattern) as a reference[10], because the normal gait pattern is effective to increase the gait speed with minimal energy consumption in case of the person without disabilities[11]. The physical characteristics of the people with paraplegia, however, is completely different from that of the people without disabilities. For example, long periods of muscle inactivity lead their lower extremities to be reduced in weight, which also induce a change in the center of mass of the whole body, and to be restricted of their range of motion. Also, the degree of freedom (DoF) of the most powered exoskeletons is less than that of the human body[12] for practical reasons such as cost, weight and manufacturability. Therefore, it is difficult to expect that the paraplegics will be able to walk effectively with the normal gait pattern; a novel gait pattern of the powered exoskeleton is necessary.

Another point is that the powered exoskeleton up to nowadays provide the same gait pattern and the humans need to adapt to the provided gait pattern through the months of training[13], [14]. It may be not appropriate since every individuals has different types of desired gait pattern which they feel more stable, or comfortable. The gait pattern for the individuals may be different depending on various factors; physical properties of the paraplegics (SCI level, body parameters, weight, muscular strength of the upper body), mechanical properties of the powered exoskeleton(power of the actuators, weight of the system, length of the crutches, shoe elasticity), training (period, method), etc. Since these factors are rarely predictable or controllable, then an iterative way to adapt the powered exoskeleton to the human based on the accumulated data is required.

In this paper, a new gait pattern for paraplegics to walk by the help of the powered exoskeleton is proposed. An adaptive gait pattern generation method developed with iterative learning, named human iterative learning algorithm is applied to the proposed gait pattern. The proposed algorithm ensures the gait stability and safety by minimizing the error of the ground contact time between the setting and the actual one by learning the walking data of the paraplegics. In this paper, the proposed gait pattern is applied to the WalkON Suit, which is a powered exoskeleton developed by ANGEL ROBOTICS CO.[15], and its effectiveness is verified by experiments.

*This work was supported by the Technology Innovation Program [or Industrial Strategic Technology Development Program (20003914)] funded by the Ministry of Trade, Industry and Energy(MOTIE, South Korea).

K.W. Park, J. Park, and K. Kong are with the Department of Mechanical Engineering, Korea Advanced Institute of Science and Technology, Daejeon, Korea {kyeongwon.park, jeongsu.park, kckong}@kaist.ac.kr

J. Choi is with the Department of Robotics Engineering, Yeungnam University, Gyeongsan, Korea jschoi@yu.ac.kr

II. GAIT PATTERN OF A POWERED EXOSKELETON

To assist people with complete paraplegia by the powered exoskeleton, a number of conditions for the system are characterized as follows:

- 1) In order to fully control the center of mass (CoM) of the entire system (i.e., the powered exoskeleton with the paraplegic) in the sagittal plane, the lower limb of the powered exoskeleton has at least three degrees of freedom including hip, knee, and ankle joints. The movements in the coronal and transverse planes are directly controlled by the paraplegic using crutches.
- 2) A gait cycle of the powered exoskeleton is divided into two gait phases, swing and stance. The trajectories for each gait phase are generated before the operation of the powered exoskeleton. The trajectories are switched with each other by button action of the user, and the powered exoskeleton can walk continuously if the button stays pressed.
- 3) The beginning of the swing (the initial swing) is defined to be 0% of the gait cycle, and the end of the swing (the terminal swing) is 50% of the gait cycle. The start of the stance (the initial contact, 50% of the gait cycle) occurs at the same time as the end of the swing, and the end of the stance (the terminal stance) is 100% of the gait cycle. Therefore, the swing foot is desired to contact the ground at each 50% of the gait cycle in the ideal situation.

The actual ground contact time, however, gets different from the desired ground contact time depending on the body inclination angle at the end of the swing. Figure 1.(a) shows late ground contact by leaning backward, which is not safe because the stance motion starts in the air before the weight of the user is transferred to the next leg. Figure 1.(b) shows the early ground contact by inclining forward, which also ruins gait stability by causing a big impact due to continuous extension of the joints. If the ground contact occurs at the desired time as shown in Fig. 1.(c) by adjusting the body inclination angle during walking appropriately, the powered exoskeleton can effectively assist the paraplegic while maintaining stability. Therefore, the gait pattern for

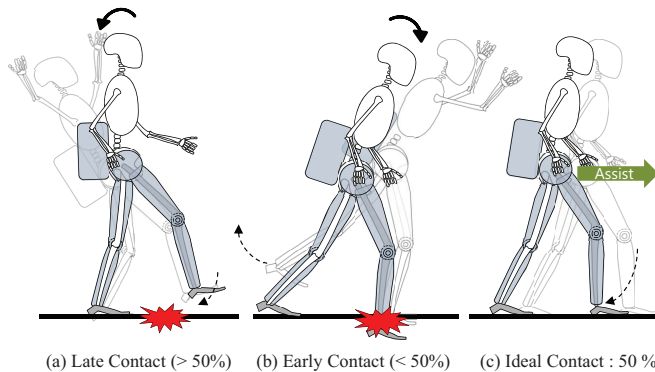

Fig. 1. Three cases of the ground contact with the powered exoskeleton; (a) early contact, (b) late contact, and (c) ideal contact

the powered exoskeleton need to consider two factors to fully assist the paraplegics: 1) the body inclination angle during walking, and 2) the compensation method for the individual not to have erroneous ground contact time.

Figure. 2 shows the configuration of the powered exoskeleton at the moment of the initial contact. Notice that the shank of the front leg is positioned to be perpendicular to the ground depending on the body inclination angle. Each joint angle of the proposed gait pattern can be defined as,

$$\theta_{hip}^f = \frac{1}{l_{th}} \arccos \lambda + v, \quad (1)$$

$$\theta_{knee}^f = \theta_{hip}^f - v, \quad (2)$$

$$\theta_{ankle}^f = 0, \quad (3)$$

$$\theta_{ankle}^i = v - \theta_{hip}^i + \theta_{knee}^i \quad (4)$$

where

$$\lambda = l_{th} \cos(v - \theta_{hip}^i) + l_{sh} \cos(v - \theta_{hip}^i + \theta_{knee}^i) - l_{sh}. \quad (5)$$

l_{sh} , l_{th} , θ_{hip}^i and θ_{knee}^i represent the length of shank, the length of thigh, and target values of the hip and knee joints based on the range of motion (RoM) of the paraplegics data, respectively. The RoM has to be considered because many of the paraplegics experience joint contracture[16]. In this paper, v stands for *virtual* body inclination angle, which is an assumed value for the posture generation. Note some advantages of the proposed gait pattern. The most unstable moment for paraplegics during walking is the initial swing[17], because the instability is caused by sudden downsize of the Base of Support (BoS) as the trailing leg falls from the ground. With the proposed pattern, the Center of Gravity (CoG) of the entire system is positioned close to the reduced BoS, making the user easier to maintain balance.

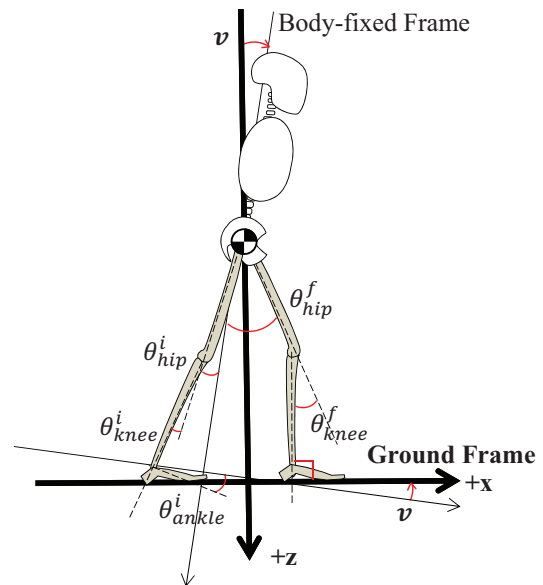

Fig. 2. A new gait pattern for a powered exoskeleton in which body inclination angle is taking account.

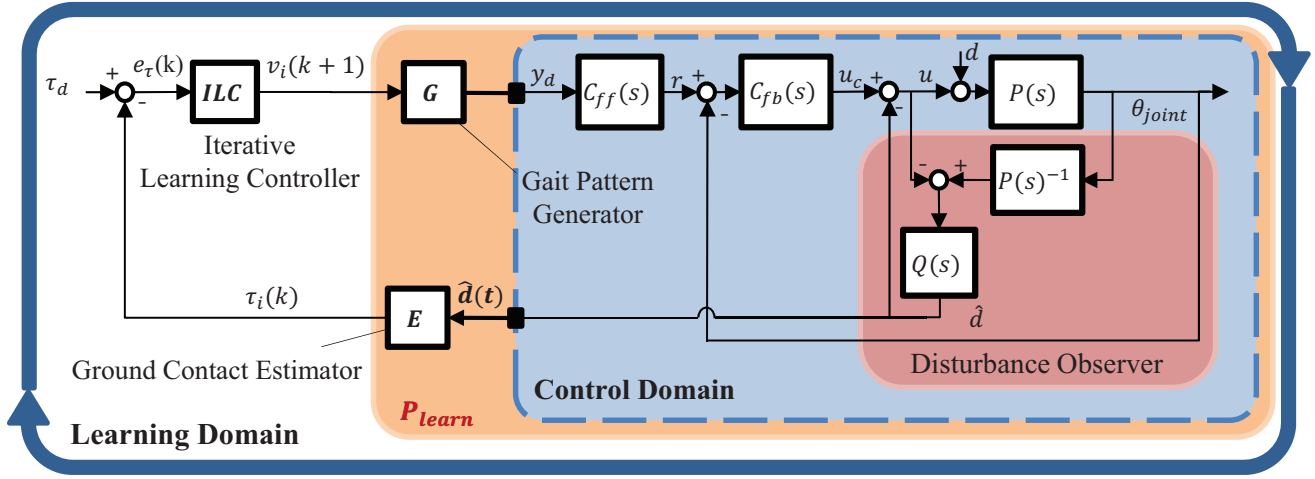

Fig. 3. Overall diagram of the Human iterative learning algorithm

III. GAIT PATTERN ADAPTATION BY HUMAN ITERATIVE LEARNING ALGORITHM

The body inclination angle right before the end of the swing phase can be varied by the factors described in Section I. Note that the variables of the powered exoskeleton can be rarely predicted or controlled exactly because a human is intervened. Therefore, an iterative way to determine v is necessary to compensate the gait pattern for each individual. This paper proposes a human iterative learning (HIL) algorithm to control the ground contact time by iterative learning control[18] based on the data during walking. The overall block diagram of the HIL represented in Fig. 3 can be described as follows.

- 1) The HIL can be divided into control domain and learning domain. The control domain contains the disturbance observer (DOB)[19] and the feedforward controller to robustly track the pre-defined gait trajectories for each joint. The DOB is utilized not only for nominalizing the plant model but also estimating the disturbances to the actuators. For these purposes, the loop of the control domain need to be operated in a short period of milliseconds.
- 2) On the other hand, the loop of the learning domain is performed once when the latest N groups of walking data are accumulated, where N is defined as a learning rate in this paper. A group of walking data is collected until the control domain is totally terminated. The bold lines shown in Fig. 3 are the data array, and the estimated disturbance data array from the DOB averaged for each sampling time is sent to the learning domain to estimate the ground contact time.
- 3) The learning domain contains three major blocks; the ground contact estimator, the iterative learning controller of which output is v , and the gait pattern generator. The iterative learning controller adjusts the body inclination angle from the ground contact error, then the gait pattern generator compensates the gait trajectories by (1), (2), (3).

Note that the iterative learning control in (c) is selected for adjusting v because the problem can be interpreted as a regulation control problem since the reference is 50% of the whole gait cycle, i.e., constant value. It is expected that the application of the iterative learning controller can show good performance to control a repeated reference while recycling previous output.

To define the nominal system for the learning domain as shown in Fig. 3, the ground contact time array (output) should be collected first when the initial virtual body inclination array (input) is inserted. The input array of the first iteration is defined by,

$$\mathbf{V}_0 = \begin{bmatrix} v_0(0) \\ v_0(1) \\ \vdots \\ v_0(N-1) \end{bmatrix} \in \mathbb{R}^N. \quad (6)$$

The elements of \mathbf{V}_0 are determined by the ROM of the ankle as,

$$v_0(k) = \left(\frac{\bar{v} - \underline{v}}{N-1} \right) k + \underline{v}, \quad k = 0, 1, \dots, N-1 \quad (7)$$

where

$$\bar{v} = \theta_{hip}^i - \theta_{knee}^i + \bar{\theta}_{ankle}. \quad (8)$$

\underline{v} and $\bar{\theta}_{ankle}$ represents the minimum value of the desired body inclination angle and the maximum angle that the ankle joint can dorsiflex, respectively. \underline{v} should be set as positive value. The equation (7) is obtained from linear interpolation between the range of possible body inclination angles at the end of the stance phase.

For each element of the initial virtual body inclination array (\mathbf{V}_0), the output array is measured by the ground contact estimator as follows,

$$\mathbf{T}_0 = \begin{bmatrix} \tau_0(0) \\ \tau_0(1) \\ \vdots \\ \tau_0(N-1) \end{bmatrix} \in \mathbb{R}^N. \quad (9)$$

The relationship between the adjusted body inclination angle and the ground contact time can be expressed as,

$$\tau(k) = P_{learn}(z)v(k), \quad k = 0, 1, \dots, N-1 \quad (10)$$

where $P_{learn}(z)$ is the discretized transfer function between τ and v . The equation above can be expressed using matrix form,

$$\mathbf{T}_0 = \mathbf{P}_{learn} \mathbf{V}_0 \quad (11)$$

where

$$\mathbf{P}_{learn} = \begin{bmatrix} p(0) & 0 & \dots & 0 \\ p(1) & p(0) & \dots & 0 \\ \vdots & \vdots & \ddots & \vdots \\ p(N-1) & p(N-2) & \dots & p(0) \end{bmatrix} \in \mathbb{R}^{N \times N}. \quad (12)$$

$p(k)$ is the k -th impulse response of $P_{learn}(z)$ in the learning domain. $p(k)$ can be solved by the data expressed above,

$$p(k) = \frac{1}{v_0(0)} \left(\tau_0(k) - \sum_{i=0}^{k-1} p(i)v_0(k-i) \right) \quad (13)$$

for $k = 0, 1, \dots, N-1$.

The iterative learning controller in the learning domain generates an updated body inclination array by the following control law:

$$\mathbf{V}_{i+1} = \mathbf{V}_i + k_r \mathbf{P}_{learn}^{-1} [\mathbf{R} - \mathbf{T}_i] \quad (14)$$

where \mathbf{R} represents the desired output array, which is exactly 50% of the gait cycle and k_r represents the update gain. As the number of iteration of learning domain goes to infinity, the ground contact error converges to zero since the error array is expressed as,

$$\mathbf{E}_{i+1} = \mathbf{R} - \mathbf{T}_{i+1} = (1 - k_r) \mathbf{E}_i. \quad (15)$$

Hence the error array is ensured to be zero as the iteration goes by if,

$$0 < k_r < 2. \quad (16)$$

IV. EXPERIMENTAL RESULTS

A. Experimental Setup

In order to verify the performance of the proposed gait pattern, an experimental setup shown in Fig. 4, the WalkON Suit manufactured by ANGEL ROBOTICS CO. is utilized. Figure 4(a) represents the overall structure of the WalkON Suit, and Fig. 4(b) represents the detailed mechanical components. Note that the WalkON Suit has active joints for the hip, knee and ankle. The hip and knee joints are actuated by the brushless motors (MF0127020 manufactured by Alliedmotion Co.) equipped with a set of planetary gears. The overall gear ratio is about 20:1, and the maximum joint torque for each joint is 70 N·m. The ankle joint is controlled by a linear actuator of which the thrust force is 1500 N.

Before the gait adaptation by iterative learning is implemented, the problem of ground contact error appears as shown in Fig. 5. Figure 5(a) represents the snapshots of the swing leg of the paraplegic in the late contact. Notice that the swing foot is still in the air even if the

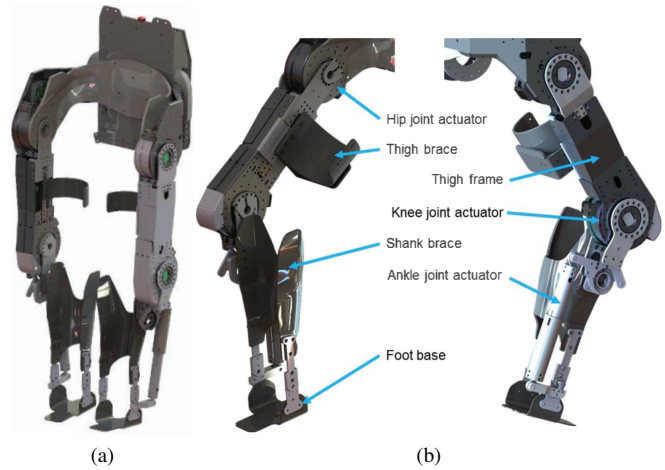
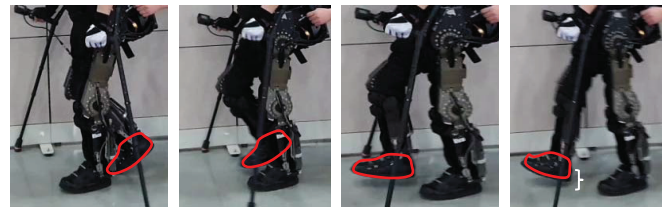

Fig. 4. WalkON Suit, the powered exoskeleton for the paraplegics; (a) the WalkON Suit and (b) the mechanical components of the lower limb



(a)



(b)

Fig. 5. The ground contact error with WalkON Suit; (a) late contact: the swing motion of the powered exoskeleton is already ended, but the ground contact doesn't occur and (b) early contact: the swing foot touches the ground during motion which causes a big impact to the user.

stance motion has started, which refers to the balance of the powered exoskeleton has broken by leaning backward. Fig 5(b) represents the snapshots of the swing leg in the early contact. The foot is caught by the ground during swinging, and the knee extension of the swing leg pushes the user backward. The proposed methods can be verified by solving these problems related to the ground contact.

B. Verification by Human Walking

The performance of the proposed method is verified by the human walking experiments of two complete paraplegics. The subject A, Byeongwook Kim, was injured by an out-car traffic accident on October, 1998. The subject A got the fracture and dislocation of thoracic spine T11-T12 resulting complete transection of spinal cord and cauda equina injury. After internal fixation of spine from T10 to L1, he was diagnosed as complete paraplegia and classified as T10/T10 sensory level, ASIA-A injury. The subject B, Juhyun Lee,

TABLE I
DETAILS OF THE SUBJECTS

Subject	Sex	Age	SCI level	AIS	Weight(kg)	Height(m)
A	Male	46	T9	A	77	1.72
B	Female	18	T12	A	48	1.63

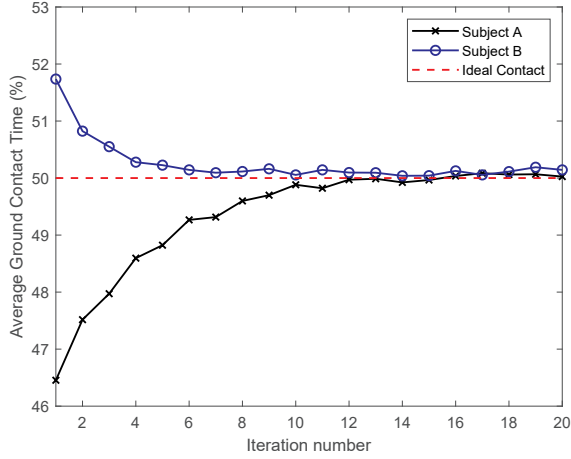

Fig. 6. Experimental results of Human Iterative Learning

was injured by an out-car traffic accident on March, 2019. The subject B was diagnosed as complete paraplegia and classified as T12/L1 sensory level, ASIA-A injury. The detailed information of the paraplegics are described in Table I.

The performance of the adaptive gait pattern is evaluated by human walking experiments. The settings of the powered exoskeleton is $N = 50$, $\underline{v} = 0$, $k_r = 0.035$, and the swing time to be 0.8 s for the subject A, 0.75 s for the subject B. The loop of the control domain has sampling time of 1.5 ms. The total iteration number of the learning loop in this experiment is 20.

Figure 6 shows results of the human iterative learning. The graphs shown in Figure 6 represent the average ground contact time for each iteration of the learning domain. The subject A showed the early contact and the subject B showed the late contact at the first iteration. As the iteration goes by, the ground contact successfully converges to 50% of a gait cycle. Note that the number of iterations until the convergence is different for each subject, even the update gain (k_r) and the learning rate (N) of the HIL are same. This is because the human also adapts to the powered exoskeleton, and the subject with better level of the SCI level may have advantages for using the powered exoskeleton. The parameters of the HIL should be selected in consideration of the properties of paraplegics.

A band of the generated swing trajectories for hip and knee joints is shown in Fig. 7. The initial values of the swing trajectories are $\theta_{hip}^i = -7^\circ$, $\theta_{knee}^i = 7^\circ$ for the subject A, and $\theta_{hip}^i = -9^\circ$, $\theta_{knee}^i = 4^\circ$ for the subject B respectively considering the ROM in (5). The final values, which are

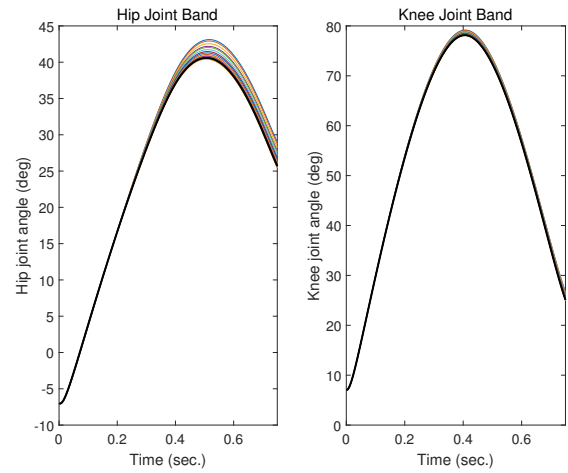

(a)

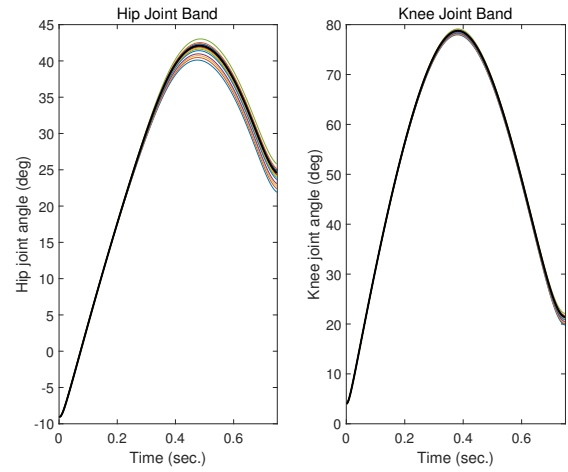

(b)

Fig. 7. A band of the swing trajectories for (a) the subject A, and (b) the subject B during iterations. The bold lines represent the trajectories from the final iteration.

the joint angles nearby the ground contact have changed to make the shank vertical to the ground, as the virtual body inclination angle is updated. As the iteration goes by, the virtual body inclination angle (v) also converges to a constant. The average values of \mathbf{V}_{20} are 3.1325 for the subject A, 2.375 for the subject B. Note that as v increases, the powered exoskeleton induces the user to tilt his body more, and also to increase the stride length(See (1), (2)). The data suggest that the HIL can be applied to find the personal gait pattern for the people with disabilities in walking, like normal people who have all different walking characteristics.

Since the negative effects shown in Fig. 5 rarely happen during walking, the paraplegics are expected to walk faster and safer while maintaining balance. The snapshots of the adapted gait pattern after the iterations is shown in Fig. 8 for each subjects. The paraplegics are able to walk in the setting of swing time 0.8 s, and 0.75 s respectively which shows the possibility to walk as the normal with the assistance of the powered exoskeleton.

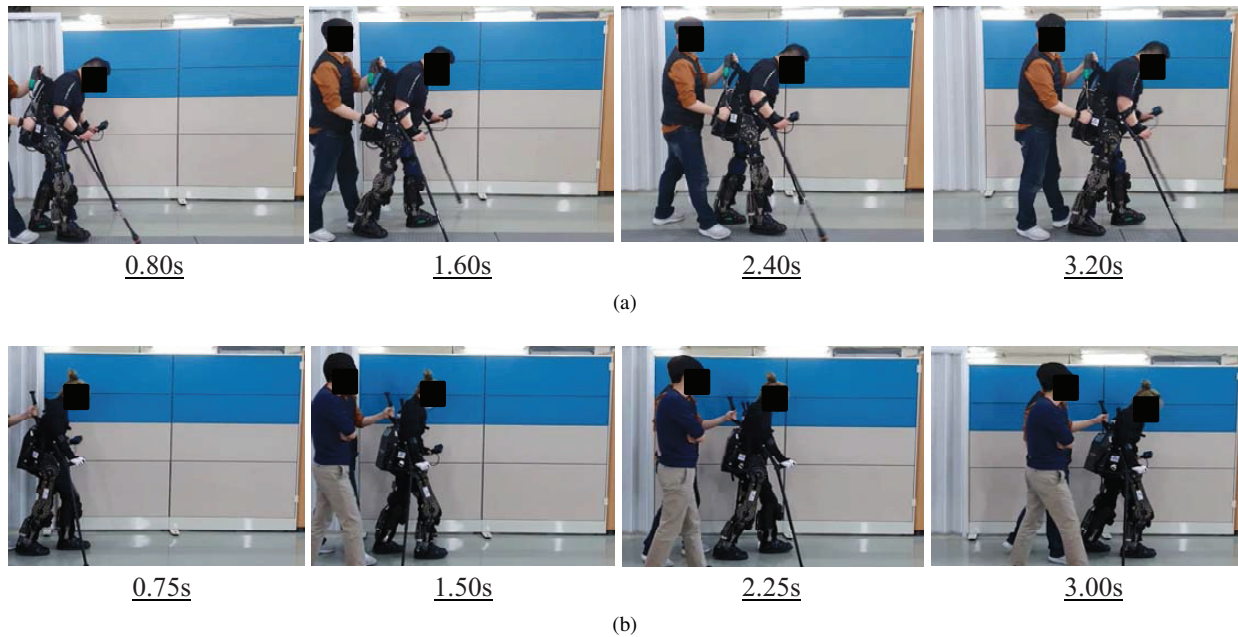

Fig. 8. Stable and safe gait pattern adapted for each paraplegic; (a) the subject A and (b) the subject B in the experiment.

V. CONCLUSIONS

In this paper, a novel gait pattern of a powered exoskeleton to assist the people with complete spinal cord injury was proposed. For paraplegics to maintain stability while walking continuously, the synchronization of gait phases between the actual and the intended should be significantly considered. For this purpose, the accumulated data of human was utilized as an input of the gait adaptation algorithm. The effectiveness of the proposed gait pattern was verified by experiments. The adaptive gait pattern proposed in this paper may provide the possibility of the paraplegics to do their daily lives. Daily lives with the powered exoskeleton can be achieved when the safety and comfortability issues are fully solved. This paper showed that the asynchronization of the robot's intention and the actual behavior of the user can be solved by a control method, and showed a distinct way for a paraplegic to walk with the powered exoskeleton.

ACKNOWLEDGMENT

The authors thank Byeongwook Kim and Juhyun Lee for their contribution and desire to overcome their difficulty.

REFERENCES

- [1] J. Bickenbach, A. Officer, T. Shakespeare, P. von Groote, W. H. Organization *et al.*, *International perspectives on spinal cord injury*. World Health Organization, 2013.
- [2] N.-H. White and N.-H. Black, "Spinal cord injury (sci) facts and figures at a glance," *Birmingham: National Spinal Cord Injury Statistical Center, Facts and Figures at a Glance*, 2016.
- [3] J. Wall, "Preventing pressure sores among wheelchair users," *Professional nurse (London, England)*, vol. 15, no. 5, p. 321, 2000.
- [4] J. Michael, J. S. Krause, and D. P. Lammertse, "Recent trends in mortality and causes of death among persons with spinal cord injury," *Archives of physical medicine and rehabilitation*, vol. 80, no. 11, pp. 1411–1419, 1999.
- [5] M. J. DeVivo, "Epidemiology of traumatic spinal cord injury: trends and future implications," *Spinal cord*, vol. 50, no. 5, pp. 365–372, 2012.
- [6] G. Zeilig, H. Weingarden, M. Zwecker, I. Dudkiewicz, A. Bloch, and A. Esquenazi, "Safety and tolerance of the rewalk™ exoskeleton suit for ambulation by people with complete spinal cord injury: a pilot study," *The journal of spinal cord medicine*, vol. 35, no. 2, pp. 96–101, 2012.
- [7] *ReWalk Robotics*. [Online]. Available: <http://rewalk.com>
- [8] *Ekso Bionics*. [Online]. Available: <http://eksobionics.com>
- [9] *Paker Hammifn*. [Online]. Available: <http://www.indego.com/indego/en/home>
- [10] J. L. Contreras-Vidal, N. A. Bhagat, J. Brantley, J. G. Cruz-Garza, Y. He, Q. Manley, S. Nakagome, K. Nathan, S. H. Tan, F. Zhu *et al.*, "Powered exoskeletons for bipedal locomotion after spinal cord injury," *Journal of neural engineering*, vol. 13, no. 3, p. 031001, 2016.
- [11] R. L. Waters and S. Mulroy, "The energy expenditure of normal and pathologic gait," *Gait & posture*, vol. 9, no. 3, pp. 207–231, 1999.
- [12] S. R. Chang, R. Kobetic, M. L. Audu, R. D. Quinn, and R. J. Triolo, "Powered lower-limb exoskeletons to restore gait for individuals with paraplegia—a review," *Case orthopaedic journal*, vol. 12, no. 1, p. 75, 2015.
- [13] P. K. Asselin, M. Avedissian, S. Knezevic, S. Kornfeld, and A. M. Spungen, "Training persons with spinal cord injury to ambulate using a powered exoskeleton," *JoVE (Journal of Visualized Experiments)*, no. 112, p. e54071, 2016.
- [14] A. Kozlowski, T. Bryce, and M. Dijkers, "Time and effort required by persons with spinal cord injury to learn to use a powered exoskeleton for assisted walking," *Topics in spinal cord injury rehabilitation*, vol. 21, no. 2, pp. 110–121, 2015.
- [15] J. Choi, B. Na, P.-G. Jung, D.-w. Rha, and K. Kong, "Walkon suit: a medalist in the powered exoskeleton race of cybathlon 2016," *IEEE Robotics & Automation Magazine*, vol. 24, no. 4, pp. 75–86, 2017.
- [16] L. Harvey and R. Herbert, "Muscle stretching for treatment and prevention of contracture in people with spinal cord injury," *Spinal cord*, vol. 40, no. 1, pp. 1–9, 2002.
- [17] T. Bajd, A. Kralj, and T. Karcnik, "Unstable states in four-legged locomotion," in *Proceedings of IEEE/RSJ International Conference on Intelligent Robots and Systems (IROS'94)*, vol. 2. IEEE, 1994, pp. 1019–1025.
- [18] H.-S. Ahn, Y. Chen, and K. L. Moore, "Iterative learning control: Brief survey and categorization," *IEEE Transactions on Systems, Man, and Cybernetics, Part C (Applications and Reviews)*, vol. 37, no. 6, pp. 1099–1121, 2007.
- [19] W.-H. Chen, "Disturbance observer based control for nonlinear systems," *IEEE/ASME transactions on mechatronics*, vol. 9, no. 4, pp. 706–710, 2004.